

Battery Charger (for lead-acid battery)

Important Safety Instructions

WARNING Shock and Energy Hazards

Be sure to read the safety guidelines and pay attention to all cautions and warnings throughout the installation procedure. The installer is responsible for ensuring compliance with the installation codes for your particular application. Disconnect all sources of AC and DC power before proceeding.

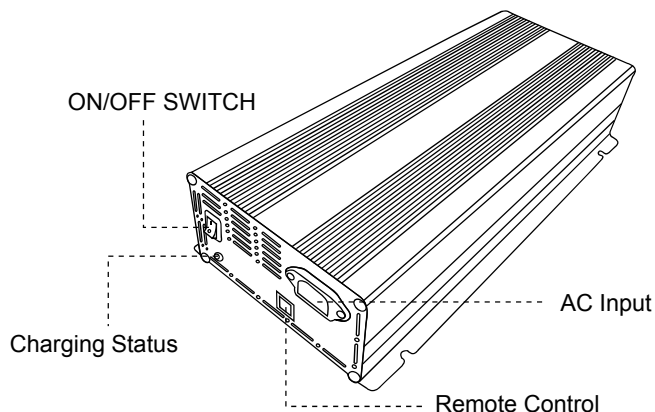

Model	HT-C-40-12	HT-C-20-24
Output current	40A(12V)	20A(24V)
Charging Type	3 stage	
Bulk Stage	14.5V(±0.5V), 40A	29.0V(±1.0V), 20A
Absorption Stage	14.5V(±0.5V), 40A-4A	29.0V(±1.0V), 20A-2A
Float Stage	13.6V±0.5, min. 0.5A (Depends on battery status)	27.2V±1, min. 0.25A (Depends on battery status)
AC input voltage	115V(90-135V) / 230V(180-270V)	
Frequency	45~65Hz	
charger efficiency	85%	
Recommended Battery Type and size	lead-acid, 200~500AH	
Remote Control	Yes	
Over Load Protection	Yes	
Over temp. Protection	Yes	
Output Reverse Protection	fuse blow	
Operating temp	0°C~40°C	
storage temp	-25°C~70°C	
Battery connection	1 pos. terminal, 1 neg. terminal	
Dimension (L.W.H)/mm	380 x 179 x 82	
Net Weight (kg)	4.5	
AC Input cable	Yes	

1. Do not expose the charger to rain, snow, spray, or bilge water. To reduce risk of fire hazard, do not cover or obstruct the ventilation openings. Do not install the charger in a zero-clearance compartment. Overheating may result.
2. The charger is designed to be permanently connected to your AC and DC electrical systems.
3. Before using the charger, read all instructions and cautionary markings on the charger, the batteries, and all appropriate sections of this guide.
4. Use only attachments recommended or sold by the manufacturer. Doing otherwise may result in a risk of fire, electric shock, or injury to persons.
5. Do not disassemble the charger. Attempting to service the unit yourself may result in a risk of electrical shock or fire. Internal capacitors remain charged after all power is disconnected.
6. The charger must be provided with an equipment-grounding conductor connected to the AC input ground.
7. To reduce the risk of electrical shock, disconnect both AC and DC power from the charger before attempting any maintenance or cleaning or working on any circuits connected to the charger. Turning off controls will not reduce this risk.

8. Do not operate the charger if it has received a sharp blow, been dropped, or otherwise damaged in any way.
9. To avoid a risk of fire and electric shock, make sure that existing wiring is in good condition and that wire is not undersized. Do not operate the charger with damaged or substandard wiring.

Installation Location:

Physical requirements for installation

Condition	Description
Clean	Do not expose the charger to metal filings or any other form of conductive contamination. The presence of conductive contamination can cause damage and void your warranty.
Cool	For best performance, the ambient air temperature should be between 32°F (0°C) and 95°F (30°C)- the cooler the better. At higher ambient temperatures, the output current will be automatically reduced to protect the charger from high internal temperatures.
Dry	The unit is intended for use in a dry location. Do not allow water or other fluids to drip or splash on the charger. Do not mount the charger in an area subject to rain, spray or splashing bilge water.
Safe	This battery charger is Ignition Protected, so it can be installed in areas containing gasoline tanks or fittings which usually require Ignition Protected equipment. It is safest not to install electrical equipment in these areas.
Ventilated	Allow at least 4 inches (10 cm) of clearance around all sides of the charger for air flow. Ensure that the ventilation openings on the unit are not obstructed. If mounting in a compartment, ventilate the compartment with louvres or cut-outs to prevent overheating.
Close to AC junction box	Avoid the use of extended wire lengths if possible.
Close to batteries	Avoid excessive cable lengths and use the recommended wire lengths and sizes. Undersized or overly long cables may affect charging accuracy.

Installation Illustration

- Before charging, read the instructions; for indoor use only. Disconnect the supply before making or breaking the connections to the battery.

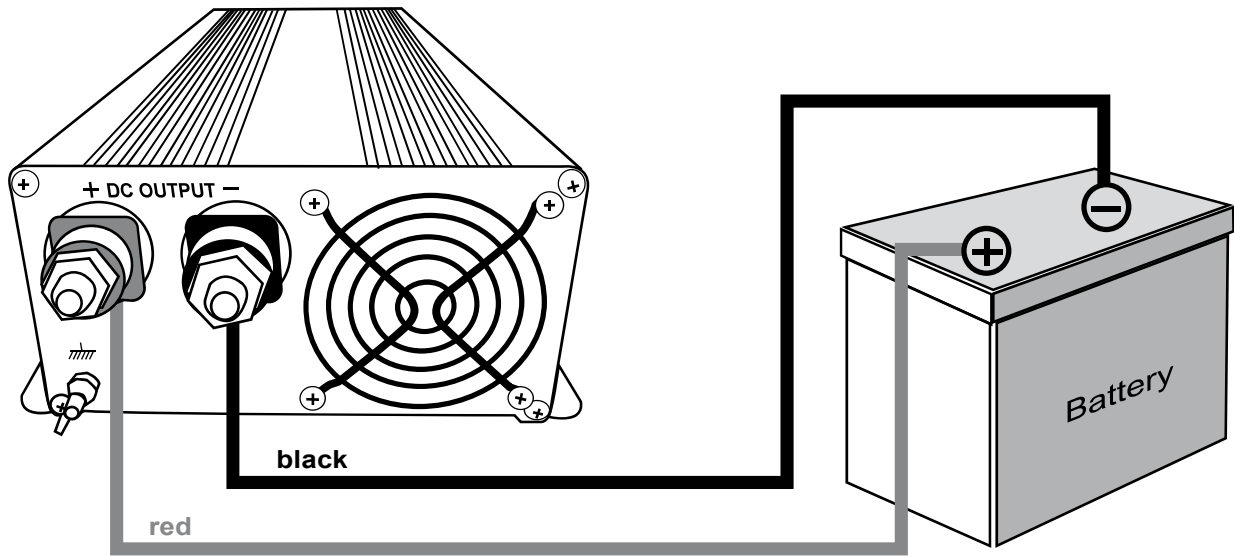

WARNING:

Explosive gases; Prevent flames and sparks; Provide adequate ventilation during charging. Include a warning against recharging non-rechargeable batteries. If the supply cord is damaged, it must be replaced by a special cord or assembly available from the manufacturer or its service agent.

Explosive gas precautions

1. The charger have been approved as Ignition Protected. They may be installed in areas containing gasoline tanks and fittings which require Ignition Protected equipment. It is safest not to install electrical equipment in these areas.
2. To reduce the risk of battery explosion, follow these instructions and those published by the battery manufacturer and the manufacturer of the equipment in which the battery is installed.
3. Working in the vicinity of lead-acid batteries is dangerous. Batteries generate explosive gases during normal operation. Therefore you must read this guide and follow the instructions exactly before installing or using your charger.

Isolated Design

The DC battery charging circuits of this charger are galvanically isolated by a transformer from the AC power circuits. This feature reduces the risk of electric shock and helps to prevent corrosion problems in marine applications.

Fixed Voltage Mode (13.5V, 40A power supply for 12V; 27.0V, 20A power supply for 24V)

The fixed voltage mode setting is meant to be used as a power supply or battery eliminator. It is not meant for charging batteries. The battery type, battery temperature, and equalize switches are all ignored in fixed voltage mode. The remote battery temperature sensor does not compensate the voltage, but the battery over-temperature shutdown is still active.

Remote Control

Remote panel: The remote panel allows you to monitor the charging progress of the battery, the total charge current, and charger status from a convenient location.

Indicator Lights and Settings on the Remote Control

- ① DC power supply switch: 13.5 volt(12V); 27.0 volt(24V)
- ② Battery charger switch
- ③ DC power supply LED Indicator
- ④ Battery charger LED Indicator
- ⑤ Temperature Fault
- ⑥ Battery Capacity
- ⑦ Charging voltage
- ⑧ Charging current

